

Where to buy :

Anti Piracy Pumps

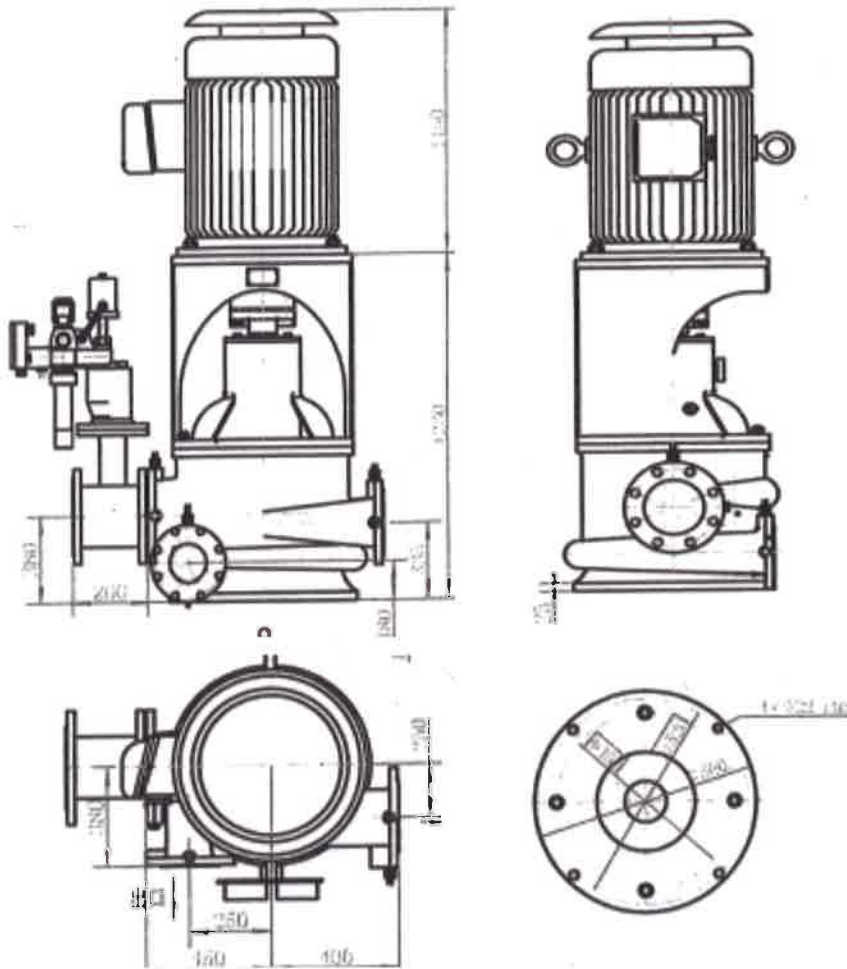

Fire, bilge & ballast pump complete
- Anti-Piracy and Security -
600/90 M3/H-30/90M-0-12M - 110KW - 1750R/MIN
- Total net weight 1900 kg -
Brass Material - LR Class Certification

Supplied by :

SCARDANA®

Tel: (1) 450-465-6556

Fax: (1) 450-671-3898

E-mail: sales@scardana.com

Web: www.scardana.com

